



OceanStor Dorado 5000/6000 All-Flash Storage Systems

Leading Performance with Innovative Hardware

30% higher performance than the previous generation
 E2E NVMe for 0.05 ms of ultra-low latency
 FlashLink® intelligent algorithms
 SCM intelligent cache acceleration for 60% lower latency
 Distributed file system OceanFS with 30% higher performance

Efficient O&M with Intelligent Edge-Cloud Synergy

3-layer intelligent management:

- 365-day capacity trends prediction
- 60-day performance bottleneck prediction
- 14-day disk fault prediction
- Immediate solutions for 93% of problems

SAN&NAS&object convergence, and cross-gen device convergence for efficient resource utilization
 FlashEver: No data migration over 10 years for cross-gen systems

Always-On Applications with 5-Layer Reliability

Component reliability: Wear leveling and anti-wear leveling
 Architecture and product reliability: 0 data loss in the event of failures of controllers, disk enclosures, or three disks
 Solution and cloud reliability: The industry's only active-active solution for SAN and NAS, geo-redundant 3DC/4DC solution, and the industry's only SOCC solution and gateway-free cloud backup

Huawei OceanStor Dorado 5000/6000 all-flash storage systems are mid-range storage systems in the OceanStor Dorado all-flash series, and are designed to provide excellent data service experience for enterprises. Both products are equipped with innovative hardware platform, intelligent FlashLink® algorithms, and an end-to-end (E2E) NVMe architecture, ensuring the storage systems deliver a 30% higher performance than the previous generation, and achieve the latency down to just 0.05 ms. The intelligent algorithms are built into the storage system to make storage more intelligent during the application operations.

Furthermore, the five-level reliability design ensures the continuity of core business.

Excelling in scenarios such as OLTP/OLAP databases, server virtualization, VDI, and resource consolidation, OceanStor Dorado 5000/6000 all-flash storage systems are smart choices for medium and large enterprises, and have already been widely adopted in the finance, government, healthcare, education, energy, and manufacturing fields. The storage systems are ready to maximize your return on investment (ROI) and benefit diverse industries.

Product Features

Ever-Fast Performance with Innovative Hardware

Innovative hardware platform:

The hardware platform of Huawei storage enables E2E data acceleration, improving the system performance by 30% compared to the previous generation.

- ✓ The intelligent multi-protocol interface module hosts the protocol parsing previously performed by the general-purpose CPU, expediting the front-end access performance by 20%.
- ✓ The computing platform offers industry-leading performance with 25% higher computing power than the industry average.

FlashLink®



- ✓ The intelligent accelerator module analyzes and understands I/O rules of multiple application models based on machine learning frameworks to implement intelligent prefetching of memory space. This improves the read cache hit ratio by 50%.
 - ✓ SmartCache + SCM intelligent multi-tier caching identifies whether or not the data is hot and uses different media to store it, reducing the latency by 60% in OLTP (100% reads) scenarios.
 - ✓ The intelligent SSD hosts the core Flash Translation Layer (FTL) algorithm, accelerating data access in SSDs and reducing the write latency by half.
- The intelligent hardware has a built-in Huawei storage fault library that accelerates component fault location and diagnosis, and shortens the fault recovery time from 2 hours to just 10 minutes.

Intelligent algorithms:

Most flash vendors lack E2E innate capabilities to ensure full performance from their SSDs. OceanStor Dorado 5000/6000 all-flash storage systems run industry-leading FlashLink® intelligent algorithms based on self-developed controllers, disk enclosures, and operating systems.

- ✓ **Many-core balancing algorithm:** Taps into the many-core computing power of a controller to maximize the data processing capability.
- ✓ **Service splitting algorithm:** Offloads reconstruction services from the controller enclosure to the smart SSD enclosure to ease the load pressure of the controller enclosure for more efficient I/O processing.
- ✓ **Cache acceleration algorithm:** Accelerates batch processing with the intelligent module to bring intelligence to storage systems during application operations.

The data layout between SSDs and controllers is coordinated synchronously.

- ✓ **Large-block sequential write algorithm:** Aggregates multiple discrete data blocks into a unified big data block for disk flushing, reducing write amplification and ensuring stable performance.
- ✓ **Independent metadata partitioning algorithm:** Effectively controls the performance compromise caused by garbage collection for stable performance.
- ✓ **I/O priority adjustment algorithm:** Ensures that read and write I/Os are always prioritized, shortening the access latency.

FlashLink® intelligent algorithms give full play to all flash memory and help Huawei OceanStor Dorado achieve unparalleled performance for a smoother service experience.

E2E NVMe architecture for full series:

All-flash storage has been widely adopted by enterprises to upgrade existing IT systems, but always-on service models continue to push IT system performance boundaries to a new level. Conventional SAS-based all-flash storage cannot break the bottleneck of 0.5 ms latency. NVMe all-flash storage, on the other hand, is a future-proof architecture that implements direct communication between the CPU and SSDs, shortening the transmission path.

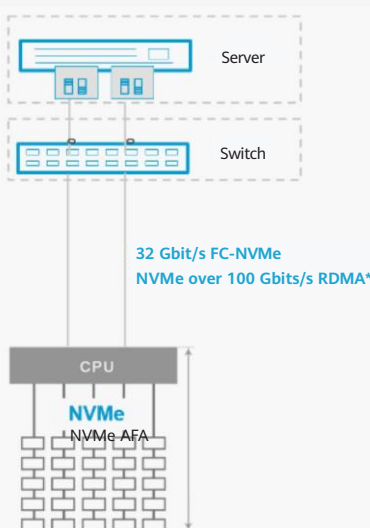

In addition, the quantity of concurrencies is increased by 65,536 times, and the protocol interaction is reduced from four times to two, which doubles the write request processing. Huawei is a pioneer in adopting end-to-end NVMe architecture across the entire series. OceanStor Dorado 5000/6000 all-flash systems use the industry-leading 32 Gb FC-NVMe/100 Gb RoCE protocols at the front end and adopt Huawei-developed link-layer protocols to implement failover within seconds and plug-and-play, thus improving the reliability and O&M. The storage systems also use a 100 Gb RDMA protocol at the back end for E2E data acceleration. This enables latency as low as 0.05 ms and 10x faster transmission than SAS all-flash storage.

Globally shared distributed file system OceanFS:

The OceanStor Dorado 5000/6000 all-flash storage systems support the NAS function and use the globally shared distributed file systems to ensure ever-fast NAS performance. To make full use of computing power, the many-core processors in a controller process services concurrently. In addition, intelligent data prefetching and layout further shorten the access latency, achieving over 30% higher NAS performance than the industry's previous benchmark.

OceanFS supports the NAS migration function, without the need of servers. It provides minute-level downtime and GB-level migration services, shortening NAS migration time and improving migration experience. File data can be tiered to OceanStor V3/V5 NAS storage and OceanStor Pacific object storage, reducing the TCO throughout the data lifecycle.

Linear increase of performance and capacity:

Unpredictable business growth requires storage to provide simple linear increases in performance as more capacity is added, to keep up with ever-changing business needs. OceanStor Dorado 5000/6000 all-flash storage systems support the scale-out up to 32 controllers, and IOPS increases linearly as the quantity of controller enclosures increases, matching the performance needs of the future business development.

Efficient O&M with Intelligent Edge-Cloud Synergy

Extreme convergence:

OceanStor Dorado 5000/6000 all-flash storage systems provide multiple functions to meet diversified service requirements, improve storage resource utilization, and effectively reduce the TCO. The storage systems provide both SAN and NAS services and support parallel access, ensuring the optimal path for dual-service access. The NAS and S3 convergence supports file and object interworking in a single instance and provides smooth evolution from file to object services. The convergence of cross-generation devices allows data to flow freely, simplifying O&M and reducing IT purchasing costs.

On and off-cloud synergy:

OceanStor Dorado 5000/6000 all-flash storage systems combine general-purpose cloud intelligence with customized edge intelligence over a built-in intelligent hardware platform, providing incremental training and deep learning for a personalized customer experience.

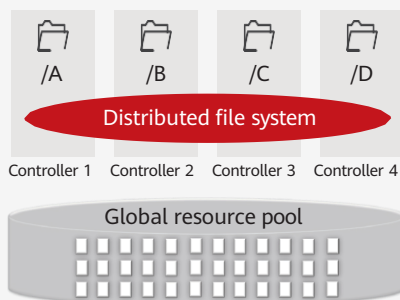

The DME IQ intelligent O&M and management platform collects and analyzes over 190,000 device patterns on the live network in real time, extracts general rules, and enhances basic O&M.

Intelligence throughout service lifecycle:

Intelligent management covers resource planning, provisioning, system tuning, risk prediction, and fault location, enables 60-day and 14-day predictions of performance bottleneck and disk faults respectively, and provides immediate solutions for 93% of problems detected.

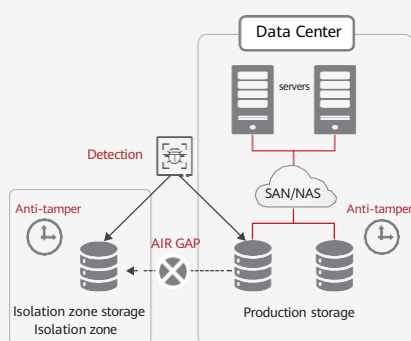

Ransomware protection:

Ransomware is a major threat to cyber resilience. Huawei OceanStor Dorado all-flash storage systems take ransomware protection to a whole new level, with three layers of ransomware interception, as well as secure snapshot and isolation zone-based recovery. These storage systems incorporate Huawei-exclusive detection and analysis engines to support ransom file interception (pre-event), real-time ransom detection (in-event), and intelligent detection (post-event). With a ransomware detection rate of 99.9%, detection capabilities have been enhanced from post-remediation to pre-event prevention. The storage systems also provide recovery in seconds with secure snapshots, mitigating the impact of ransomware attacks.

FlashEver:

The intelligent flexible architecture implements component-based upgrades without the need for data migration within 10 years. Users can enjoy latest-generation software and hardware capabilities without investing again in the related storage software features.

Always-On Applications with 5-Layer Reliability

Industries such as finance, manufacturing, and carriers are upgrading to intelligent service systems to meet the strategy of sustainable development. This will likely lead to diverse services and data types that require better IT architecture. OceanStor Dorado all-flash storage systems are an ideal choice for customers who need robust IT systems that consolidate multiple types of services for stable, always-on services. They ensure end-to-end reliability at all levels, from component, architecture, product, solution, all the way to cloud, supporting data consolidation scenarios with 99.9999% availability.



SSD

Benchmark-Setting 5-Layer Reliability

Component – SSDs:

Reliability has always been a top concern in the development of SSDs, and Huawei SSDs are a prime example of this. Leveraging global wear-leveling technology, Huawei SSDs can balance their loads for a longer lifespan of each SSD. In addition, Huawei's patented anti-wear leveling technology prevents simultaneous multi-SSD failures and improves the reliability of the entire system.

HyperMetro

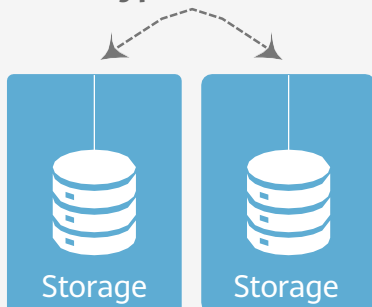

Architecture – full-mesh design:

Huawei OceanStor Dorado 5000/6000 all-flash storage systems adopt the intelligent matrix architecture (multi-controller) within a fully symmetric active-active (A-A) design to eliminate single points of failure and achieve high system availability.

Application servers can access LUNs through any controller, instead of just a single controller. Multiple controllers share workload pressure using the load balancing algorithm. If a controller fails, other controllers take over services smoothly without any service interruption.

Product – enhanced hardware and software:

Product design is a systematic process. Before a stable storage system is commercially released, it must ensure that it meets the demands from both software and hardware, and can faultlessly host key enterprise applications. The OceanStor Dorado 5000/6000 all-flash storage systems are equipped with hardware that adopts a fully redundant architecture and supports dual-port NVMe and hot swap, preventing single points of failure. The innovative 9.5 mm palm-sized SSDs and biplanar orthogonal backplane design provide 44% higher capacity density and 25% improved heat dissipation capability, and ensure stable operations of 2U 36-slot SSD enclosures. The smart SSD enclosure is the first ever to feature built-in intelligent hardware that offloads reconstruction from the controller to the smart SSD enclosure. Backed up by RAID-TP technology, the smart SSD enclosure can tolerate simultaneous failures of three SSDs and reconstruct 1 TB of data within 25 minutes. In addition, the storage systems offer comprehensive enterprise-grade features, such as 3-second periodic snapshots, which set a new standard for storage product reliability.

Solution – gateway-free active-active solution:

Flash storage is designed for enterprise applications that require zero data loss or zero application interruption. OceanStor Dorado 5000/6000 all-flash storage systems use a gateway-free A-A solution for SAN and NAS to prevent node failures, simplify deployment, and improve system reliability. In addition, the A-A solution implements A-A mirroring for load balancing and cross-site takeover without service interruption, ensuring that core applications are not affected by system breakdown. The all-flash systems provide the industry's only A-A solution for NAS, ensuring efficient, reliable NAS performance. They also offer the industry's first all-IP active-active solution for SAN, which uses long-distance RoCE transmission to improve performance by 50% compared with traditional IP solutions. The industry's only Storage + Optical Connection Coordination (SOCC) solution ensures efficient mitigation of active-active/replication link sub-health issues and completes link switchover within 2 seconds. In addition, OceanStor Dorado 5000/6000 all-flash storage systems can be smoothly upgraded to the geo-redundant 3DC/4DC solution for high-level data protection. The systems provide a professional container CDR disaster recovery (DR) plug-in to support cross-site active-active DR, cross-container cluster active/standby DR, and cross-storage integrated backup and recovery for container applications in a single cluster.

Cloud-level reliability – gateway-free migration to the cloud:

With the rise of public clouds, more backup services use public cloud object storage as their backup storage for higher cost-effectiveness and more reliable remote backup. The CloudBackup feature of Huawei OceanStor Dorado 5000/6000 all-flash storage systems follows this trend and eliminates the need to purchase backup storage devices and backup software, thereby reducing purchase and maintenance costs. The backup service supports the interworking with cloud storage services like Object Storage Service (OBS) and AWS S3, and provides incremental backup, full-copy recovery, and file-level fine-grained recovery, delivering cloud-level reliability.

Technical Specifications

Model	OceanStor Dorado 5000	OceanStor Dorado 6000
Hardware Specifications		
Maximum Number of Controllers	32	32
System Cache	256 GB-8 TB	1 TB-16 TB
Supported Storage Protocols	FC, iSCSI, FC-NVMe, NVMe over RoCE, NFS, CIFS, NDMP, S3*	
Front-End Port Types	8/16/32 Gbps FC/FC-NVMe, 10/25/40/100 GbE, 25/100 Gbps NVMe over RoCE	
Back-End Port Types	SAS 3.0/ 100Gb RDMA	
Maximum Number of Hot-Swappable I/O Modules per Controller Enclosure	12	
Maximum Number of Front-End Ports per Controller Enclosure	48	
Maximum Number of SSDs	3,200	4,800
SSDs	1.92 TB/3.84 TB/7.68 TB/15.36/30.72 TB palm-sized NVMe SSD, 960 GB/1.92 TB/3.84 TB/7.68 TB/15.36 TB SAS SSD	
SCM Supported	800 GB SCM/1.6 TB*	
Software Specifications		
Supported RAID Levels	RAID 5, RAID 6, RAID 10*, and RAID-TP (tolerates simultaneous failures of 3 SSDs)	
Number of LUNs	16,384	32,768
Value-Added Features	SmartDedupe, SmartVirtualization, SmartCompression, SmartMigration, SmartThin, SmartQoS, SmartTier*, SmartCache, SmartQuota, SmartMulti-Tenant, SmartMigration for NAS, SmartMobility, HyperSnap, HyperReplication, HyperClone, HyperMetro, HyperCDP, HyperLock, HyperEncryption, HyperDetect*, HyperLink, CloudVxLAN, CloudBackup*	
Storage Management Software	DeviceManager	UltraPath DME IQ
Physical Specifications		
Power Supply	SAS SSD enclosure: 100V-240V AC±10%, 192V-288V DC, -48V to -60V DC Controller enclosure/Smart SAS disk enclosure/Smart NVMe SSD enclosure: 200V-240V AC±10%, 100-240V AC±10%, 192V-288V DC, 260V-400V DC, -48V to -60V DC	SAS SSD enclosure: 100V-240V AC±10%, 192V-288V DC, -48V to -60V DC Controller enclosure/Smart SAS SSD enclosure/Smart NVMe SSD enclosure: 200V-240V AC±10%, 192V-288V DC, 260V-400V DC, -48V to -60V DC
Dimensions (H x W x D)	SAS controller enclosure: 86.1 mm × 447 mm × 820 mm NVMe controller enclosure: 86.1 mm × 447 mm × 920 mm SAS SSD enclosure: 86.1 mm × 447 mm × 410 mm Smart SAS SSD enclosure: 86.1 mm × 447 mm × 520 mm NVMe SSD enclosure: 86.1 mm × 447 mm × 620 mm	SAS controller enclosure: 86.1 mm × 447 mm × 820 mm NVMe controller enclosure: 86.1 mm × 447 mm × 920 mm SAS SSD enclosure: 86.1 mm × 447 mm × 410 mm Smart SAS SSD enclosure: 86.1 mm × 447 mm × 520 mm NVMe SSD enclosure: 86.1 mm × 447 mm × 620 mm
Weight (Incl. Disk Units)	SAS controller enclosure: ≤ 45 kg NVMe controller enclosure: ≤ 50 kg SAS SSD enclosure: ≤ 20 kg Smart SAS SSD enclosure: ≤ 30 kg Smart NVMe SSD enclosure: ≤ 35 kg	SAS controller enclosure: ≤ 45 kg NVMe controller enclosure: ≤ 50 kg SAS SSD enclosure: ≤ 20 kg Smart SAS SSD enclosure: ≤ 30 kg Smart NVMe SSD enclosure: ≤ 35 kg
Operating Temperature	-60 m to +1800 m altitude: 5°C to 35°C (cabinet) or 40°C (enclosure) 1800 m to 3000 m altitude: The max. temperature threshold decreases by 1°C for every altitude increase of 220 m	
Operating Humidity	10% to 90% RH	

*Contact Huawei sales staff if you need this specification.

To learn more about Huawei storage, please contact your local Huawei office or visit the Huawei Enterprise website: <http://e.huawei.com>.



Huawei Enterprise APP





Huawei IT



Copyright © Huawei Technologies Co., Ltd. 2023. All rights reserved.

No part of this document may be reproduced or transmitted in any form or by any means without the prior written consent of Huawei Technologies Co., Ltd.

Trademarks and Permissions

 , HUAWEI,  are trademarks or registered trademarks of Huawei Technologies Co., Ltd. Other trademarks, product, service and company names mentioned are the property of their respective holders.

Disclaimer

The content of this manual is provided "as is". Except as required by applicable laws, no warranties of any kind, either express or implied, including but not limited to, the implied warranties of merchantability and fitness for a particular purpose, are made in relation to the accuracy, reliability or contents of this manual.

To the maximum extent permitted by applicable law, in no case shall Huawei Technologies Co., Ltd be liable for any special, incidental, indirect, or consequential damages, or lost profits, business, revenue, data, goodwill or anticipated savings arising out of, or in connection with, the use of this manual.

HUAWEI TECHNOLOGIES CO., LTD.
Bantian Longgang District
Shenzhen 518129, P.R. China
Tel: +86-755-28780808

www.huawei.com